

# AG25 Agricultural Encoder



## Installation Manual

### 1. PREFACE

The installation instructions below are provided to connect the encoder. For more information consult the encoder datasheet on the website [www.dynaparencoders.com.br](http://www.dynaparencoders.com.br)

### 2. SAFETY

**Authorized persons:** The encoder must be installed and handled by a qualified technician as the unit contains sensitive electronic circuits.

**Risk of injury due to the rotating shaft:** Hair and clothing can become attached to the rotating shafts. Before starting the installation work, disconnect all the power supplies and ensure that the working environment is clean and safe.

**Risk of Static Electricity (ESD):** The electronic components in the encoder are very sensitive to high voltage, which can arise due to the friction of the clothing. Do not touch the connector contacts.

**Risk of destruction due to mechanical shock:** Violent mechanical shocks can lead to destruction of the optical system and ball bearings. NEVER USE FORCE TO INSTALL ENCODER! The assembly is simple, as long as the correct installation procedure is followed. If you need stronger fastenings, use the accessories that come with the product.

**Risk of destruction due to overload:** The product can only be operated within the maximum and minimum limits specified in the technical manual.

**Fields of application:** processes and controls in agricultural or industrial equipment. The connecting cable is not for in-line mounting on trailings, it is only for fixed mounting

The companies that integrate this encoder in their installations are also responsible for compliance with the CE directives

\*It is not allowed to power the encoder from a networked DC power

### 3. MOUNTING

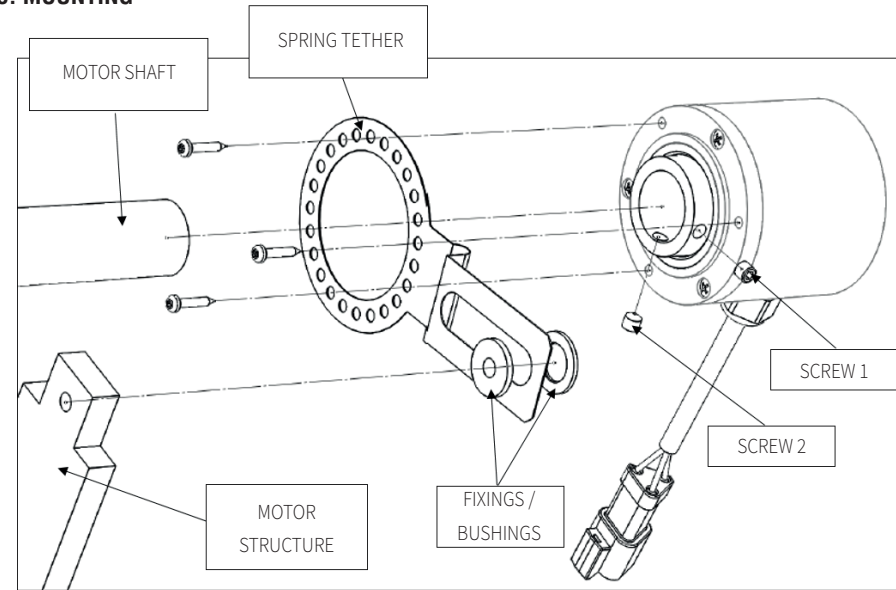

### 4. INSTALLATION INSTRUCTIONS

- 1 – Insert the encoder shaft into the motor shaft or equipment
- 2 – Attach the encoder shaft by tightening screws 1 and 2
- 3 – Attach the leaf spring to the encoder with the 3 screws
- 4 – Attach the leaf spring rod to the bolt using the anchor bolts on the motor frame or equipment (the bolt and nut are not supplied in the kit)

### 5. MECHANICAL CHARACTERISTICS



Max. rotation = 500 RPM



Operating temperature = -15°C up to 70°C

### 6. ELECTRICAL CHARACTERISTICS

<b>Power Supply</b>	5 to 26 VCC
<b>Output</b>	HTL (5-26 VCC) or TTL ( 5 VCC) 40mA maximum
<b>Consumption</b>	< 100mA
<b>Maximum Frequency</b>	300 kHz (sensor)
<b>Resolution</b>	180, 360 or 512 PPR
<b>Electrical Protection</b>	Polarity reversal, short-circuit between outputs and overvoltage
<b>Simmetry</b>	180°C ± 90°C



### Signal format



### 7. DIMENSIONAL DRAWING

