

**ACURO®**  
drive

for  
**Single  
Cable  
Solution**



---

## ACURO AD37-Series

Safe things come in small packages...  
the AD37 encoder series for your functional safety servomotor system

**HENGSTLER**



## ACURO®- AD37-Series

drive



### Absolute Motor Feedback Encoder Series AD37 for Single Cable Solution - Functional Safety

- High performance motor feedback
- Uses ACURO secure interface
- Allow users to create SIL2 and SIL3 Functional Safety Applications
- Electronic Data Sheet
- Motor and Drive data storage
- High resolution 20 Bit Singleturn, 12 Bit Multiturn
- Operating temperature of -40°C ... +115°C
- 12,000 rpm max. speed
- Shortest mounting depth
- Motor winding temperature sensor input

**Applications:** Servo Motors

**Safe things come in small packages...**

### The AD37 encoder series for your functional safety servomotor system

Safety. It is ever on our minds. In particular, systems which use servo motors to autonomously move tools and work represent a real hazard to the worker's personal safety. Increasingly, customers build systems with documented safety levels to ensure greater safety and reliability for these applications. By using standardized SIL levels, the level of safety can be independently gauged. It's for these applications that the AD37 absolute encoder series, using ACURO secure interface, was created.

The Hengstler ACURO secure interface was especially designed to provide high levels of functional safety in servo motor control systems. The interface protocol meets SIL3 requirements, while the AD37S encoder itself meets SIL2 and the AD37E encoder meets SIL3. With an operating temperature

range up to +115°C and a 12,000 rpm maximum speed, the 28 mm mounting depth of the AD37 series makes it the most compact, absolute multiturn encoder in its class! The encoder contains both an encoder temperature sensor and an input to allow connection of the motor's winding temperature sensor, putting that information directly into the encoder's data. An internal "Electronic Data Sheet" in the encoder stores motor and encoder data, and can be recalled at any time.

Safety. When you need a functional safety rating for your servo motor system, rely on the Hengstler AD37 encoder series and the ACURO secure interface!

For further information, contact Hengstler today at [info@hengstler.com](mailto:info@hengstler.com), or by phone at +49 (0) 7424 89 0.

# Technical Data

## MECHANICAL

Housing Diameter	max. 39.3 mm
Shaft	Shaft with integrated Double-Cardanic coupling hub
Mounting Depth	28 mm
Mounting Flange	Direct Flange Mount
Protection Class Shaft Input	IP40
Protection Class Housing	IP40
Shaft Load axial / radial max.	20 N / 55 N
Speed max.	6,000 - 12,000 rpm (continuous duty)
Starting Torque typ.	≤ 1 Ncm
Moment of Inertia	1.05 x 10 <sup>-6</sup> kgm <sup>2</sup>
Vibration Resistance (DIN EN 60068-2-6)	300 m/s <sup>2</sup> (10 ... 2000 Hz)
Shock Resistance (DIN EN 60068-2-27)	1,000 m/s <sup>2</sup> (6 ms)
Max. angular acceleration	2.5 x 10 <sup>5</sup> rad/sec <sup>2</sup>
Operating Temperature	-40°C ... +115°C
Storage Temperature	-30°C ... +80°C
Material Shaft	Stainless Steel
Material Housing	Aluminum / Plastic
Weight	approx. 70 g (ST or MT)
Connection (with Strain Relief)	ECU Interface - PCB connector (axial) Motor winding temperature sensor input (axial)

## ELECTRICAL

General design	as per EN IEC 61010-1, protection class III, contamination level 2, overvoltage class II
Supply voltage	7 - 12 VDC
Current w/o load (typ.)	11 V DC: <120 mA
Resolution single-turn	20 Bit standard (others available on request)
Resolution multi-turn	12 Bit (magnetic)
Electrical Interface	4Wire: RS485
Data Protocol	ACURO secure interface for Single Cable Solution
Electronic Data Sheet (EDS)	512 bytes of storage for encoder data
OEM Memory	7.5 kbytes of storage for motor and drive data
Absolute accuracy (typ.)	±36''
Repeatability (typ.)	±10''
Data retention in non-volatile MT memory (without power supply)	1 year at 120°C 14 year at 35°C

## SAFETY

Design Functional Safety	SIL2, SIL3 according to EN IEC 61508, 62061, 61800-5-2, PLd, PLe according to EN ISO 13849-1, category 3
Resolution for save position	9 Bit Singleturn
PFH-value	9.62 x 10 <sup>-10</sup> per hour
MTTFd / DCavg	482 years / 95.98%
Realizable safety function according to EN 61800-5-2	SLS (Safe limited speed) SLI (Safe limited increment) SLA (Safe limited acceleration) SDI (Safe direction) STO, SS1, SS2, SOS (Safe stop functions)

# Dimensional Drawing

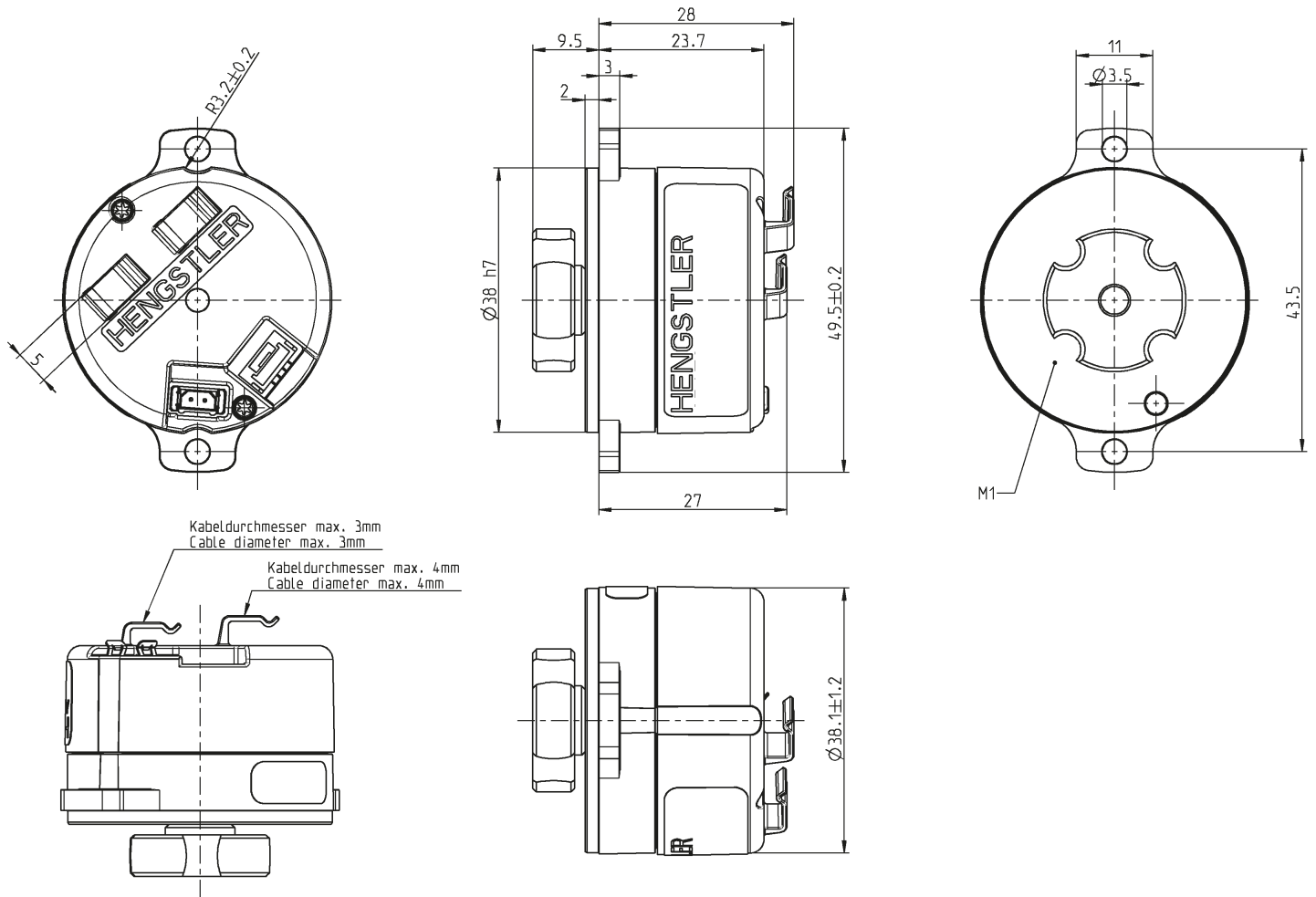

All specifications are subject to change without prior notice. DOC P3 PS2 EXAD37 S 2015-11-20 E

Type	Resolution	Supply voltage	Flange, Protection, Shaft	Interface	Connection
<b>AD37</b>	<b>0017</b> 17 Bit ST*	<b>G</b> DC 7 - 12 V	<b>Z.0W</b> Two-Eared Flange, IP40, Shaft with Integrated Coupling Hub	<b>4W</b> ACURO secure interface, 4wire	<b>9</b> Data & power supply connector, axial, 4 pole + motor temperature sensor, axial, 2 pole
	<b>0019</b> 19 Bit ST*				
<b>AD37S</b> (SIL2 PLd)	<b>0020</b> 20 Bit ST <sup>1</sup>				
<b>AD37E</b> (SIL3 PLe)	<b>1217</b> 17 Bit ST* + 12 Bit MT*			<b>2W</b> ACURO secure interface, 2wire*	
	<b>1219</b> 19 Bit ST + 12 Bit MT*				
	<b>1220</b> 20 Bit ST + 12 Bit MT <sup>1</sup>				

\* On request

<sup>1</sup> 9 Bit ST resolution for safe position

## HENGSTLER

Uhlandstr. 49 | D-78554 Aldingen | Telefon: +49 (0) 7424-89-0 | info@hengstler.com | www.hengstler.com