

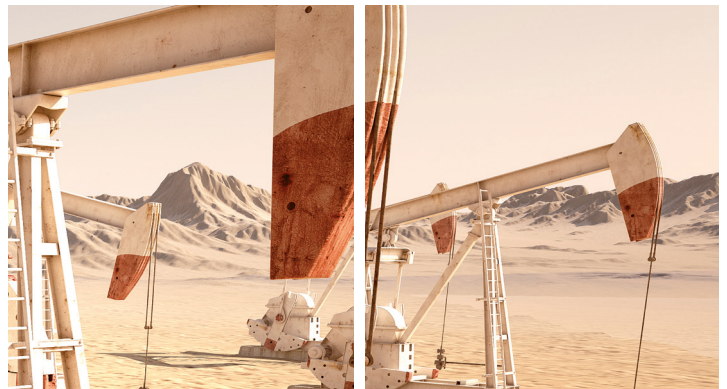

ACURO®
Xproof



ACURO AX73

Making encoder installations in hazardous environments easy

HENGSTLER



ACURO®- AX73

Xproof



Ex certified, high performance, userfriendly installation concept and robust design

- › ATEX and IECEx certification for Gas and Dust explosion proof
- › High precision standard as ACURO Industry
- › Resolution up to 22 Bit Singleturn + 12 Bit Multiturn
- › Optical encoder with a true geared multiturn
- › Interfaces: SSI/BiSS and Profibus
- › Easy and fast field installation
- › Robust design
- › Extreme corrosion resistance: high grade stainless steel housing (1.4404 / AISI 316L)
- › Protection class IP66/67

Applications: Winches, Cranes, Drills, other Oil and Gas Applications, Paint Plants, Petrochemical Facilities, Bottling Plants, Mixers, Silos, Grain Mills

Making encoder installations in hazardous environments easy

In the development of equipment for use in hazardous environments, selecting the right sensor plays a crucial role. First and foremost, explosion protection of the sensor itself is critical. Additional harsh requirements, such as the ability to withstand severe shock and vibration, and the need for corrosion resistance due to the working atmosphere, are placed on the encoder by the application itself. And, of course, an accurate and high-resolution sensor signal is required in spite of all other demands.

Hengstler has incorporated all these requirements into our new, explosion-proof, absolute encoder AX73 with SSI/BiSS and Profibus interface. With the addition of AX73, our explosion-proof product range is complete!

The optical scanning system of the AX73 encoder provides a highly accurate, high-resolution sensor signal that is also resi-

stant to the strongest external magnetic fields.

The connection concept of the AX73 allows the routing of cabling and the final encoder installation to be done in separate steps. This provides significant cost and time savings during installation, as cabling can be done in advance. Emergency servicing can also be done more quickly, due to the ability to simply unplug the encoder cable and plug it into the replacement encoder.

With its ATEX and IECEx approvals, the Hengstler AX73 is certified and approved for international use, thus providing the user a global guarantee of safety and reliability in hazardous areas.

For further information, contact Hengstler today at info@hengstler.com, or by phone at +49 (0) 7424 89-0.

Technical Data

MECHANICAL

Housing Diameter	73.5 mm / 76 mm
Shaft Diameter	10 mm
Flange (Mounting of Housing)	Clamping Flange, Bores 3xM6
Protection Class Shaft Input (EN 60529/ A1:2000-02)	IP67
Protection Class Housing (EN 60529/ A1:2000-02)	IP66/67
Shaft Load axial / radial max.	100 N / 40 N
Speed max.	3000 rpm
Nominal Speed	1500 rpm
Starting Torque typ.	≤ 4 Ncm
Moment of Inertia	approx. 30 gcm ²
Vibration Resistance (DIN EN 60068-2-6:2008)	100m/s ² (60 ... 2000Hz)
Shock Resistance (DIN EN 60068-2-27:2010)	1000m/s ² (6ms)
Ambient Temperature	-40 °C ... +70 °C
Storage Temperature	-20°C ... +80°C
Material Housing	Stainless Steel (1.4404 / 316L)
Weight	approx. 2200g
Connection	Terminal box with 2 x M20 x 1,5 screw thread, radial

ELECTRICAL

General design	as per EN 61010 - 1, protection class III contamination level 2, overvoltage class II
EMC	Noise emission as per EN 61326-1 Group1, Class B; Noise immunity as per EN 61326-1 Class A
Supply voltage	DC 10 - 30V with pole protection

ELECTRICAL Profibus

Current w/o load max.	230 mA
Recommended external fuse	T 0.25 A
Power consumption	approx. 1.5 W to 2W
Resolution singleturn	10 -14 Bit
Resolution multiturn	12 Bit
Drives	RS485
Protocol	Profibus - DP with encoder profile class C2 (can be parameterized)
Baud rate	automatically adjusted in a range from 9.6 Kbaud up to 12 Mbaud
Device address	adjustable by DIP switches or bus (optional)
Linearity	± ½ LSB (±1 LSB with resolution 13, 14, 25, 26 Bit)
Output code	Binary

ELECTRICAL SSI/BiSS

Current w/o load max.	200 mA
Recommended external fuse	T 0,25 A
Power consumption	approx.. 1,5W to 2W
Resolution singleturn	10 - 22 Bit
Resolution multiturn	12 Bit
Output code	Gray or Binary
Lines/ Drivers	Clock and Data / RS422
Control input	Direction



CLASSIFICATION

The absolute shaft encoder line ACURO-Xproof is available in explosion proof design with explosion proof enclosure under AX73. It has been assured with the EC-TYPE-Examination Certificate ITS14ATEX17991X that the AX73 meets the requirements of safety and health according to EN 60079-0:2012; EN 60079-1:2007 and EN60079-31:2009. Additionally the encoder is certified according the IECEx standards IEC 60079-0:2011; IEC 60079-1:2007-04 and IEC 60079-31:2008. Assured according IECEx ITS 14.0062X certification. Therefore it is approved for the following explosive areas:

Gas: Ex II 2 G Ex d IIC T4 Gb

Dust: Ex II 2D Ex tb IIIC T130 Db

Dimensional Drawing

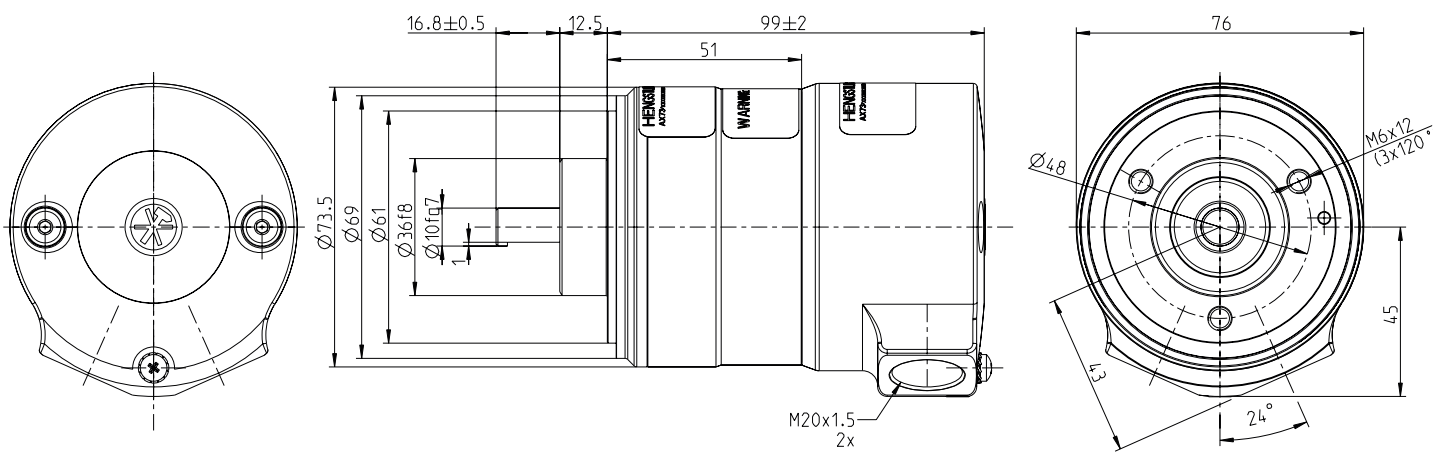

All specifications are subject to change without prior notice. DOC P3 PS2 EX AX73 2016-10-26 E

Type	Resolution	Supply Voltage	Flange, Protection, Shaft	Interface	Connection
AX73	0010 10 Bit ST	E DC 10 - 30 V	K.72 Clamping Flange, IP67, 10 mm	DP Profibus SB SSI Binary SG SSI Gray BI BiSS-B BE BiSS-C	2 2 x M20 x 1.5 screw thread, radial
	0012 12 Bit ST				
	0013 13 Bit ST				
	0014 14 Bit ST				
	0017 17 Bit ST*				
	0019 19 Bit ST*				
	0022 22 Bit ST*				
	0360 360 Incr. ST*				
	0720 720 Incr. ST*				
	1212 12 Bit MT + 12 Bit ST				
	1213 12 Bit MT + 13 Bit ST				
	1214 12 Bit MT + 14 Bit ST				
	1217 12 Bit MT + 17 Bit ST*				
1219 12 Bit MT + 19 Bit ST*					
1222 12 Bit MT + 22 Bit ST*					

*available only with SSI/BiSS interface

HENGSTLER

Uhlandstr. 49 | D-78554 Aldingen | Telefon: +49 (0) 7424-89-0 | info@hengstler.com | www.hengstler.com