

SERIES M9

Dynapar™ brand

Miniature Encoder

Key Features

- Super-Compact Modular Encoder for Small Servo and Stepper Motor Feedback
- Integrated ASIC for Enhanced Reliability and Accuracy
- Up to 512 PPR Resolution
- Ideal for Pick and Place Type Machines

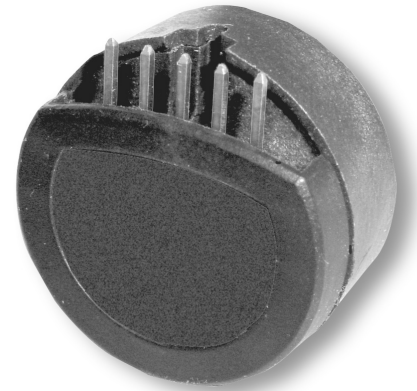

SPECIFICATIONS

STANDARD OPERATING CHARACTERISTICS

Code: Incremental, Optical
Resolution: 100 to 512 PPR (Pulses/Revolution)
Phasing: 90° ±18° electrical
Symmetry: 180° ±18° electrical
Index Pulse Width: 90° ±36° electrical

ELECTRICAL

Supply Voltage: 5 VDC ±10%
Supply Current: 10 mA, typ.
Output Signals: 2.5 V min. high (V_{OH}); 0.5 V max. low (V_{OL}), 6 mA sink/source (25°C), 4 mA (100°C)
Frequency Response: 200 kHz
Termination: 5 pin header (accessory 12" wires w/connector, part no. CA0050012) or flying leads
Recommended Mating Connector: AMP part number 103675-4

MECHANICAL

Hub Diameter: 1.5, 2.0, 2.5, 3.0, 4.0 mm; 0.125, 0.156 inch
Mounting Configuration: Modular Hollow Bore Mount
Hub Dia. Tolerance: +0.0004"/-0.0000" (+0.010 mm/-0.000 mm)
Mating Shaft Length: See table (page 2)
Mating Shaft Runout: 0.001 TIR
Mating Shaft Endplay: >256 ppr: ±0.003" (±0.076mm); 250, 256 ppr: +0.005/-0.003" (+0.127/-0.076mm); <250 ppr: +0.007/-0.003" (+0.178/-0.076mm)
Moment of Inertia: 0.15 x 10⁻⁵ oz-in-sec² (0.11 gm-cm²)
Housing and Cover: Plastic
Weight: 0.15 oz (4.14 g)

ENVIRONMENTAL

Operating Temperature: -20° to 100°C
Storage Temperature: -50° to 125°C
Humidity: Up to 90% (non-condensing)

OUTPUT WAVEFORMS & CONNECTIONS

PIN	FUNCTION	CABLE WIRE
1	GND	BLACK
2	CH Z	BLUE
3	CH A	WHITE
4	Vcc	RED
5	CH B	BROWN

(Direction CCW viewing encoder cover)

DIMENSIONS/INSTALLATION

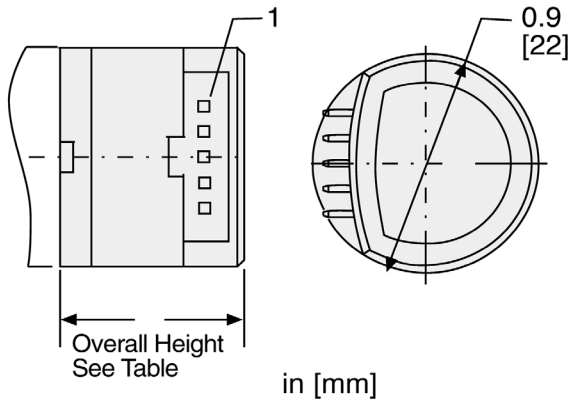

IMPORTANT: To properly install Series M9, a specialized mounting kit must be purchased. Only one kit is required to install any number of encoders with the same hub bore size.

Kit Part Number:

MK M9

Code 4 (from Models Table, above) designating Hub Bore requirement.

Example: Kit for installing encoders with 3.0 mm hub Bore= **MK M9 3.0**

Base (Code 3)	Overall Height inch (MM)	Motor Shaft Length inch (MM)	
		Max.	Min
A	0.583 (14.80)	0.437 (11.10)	0.377 (9.57)
C, D, E	0.717 (18.20)	0.571 (14.50)	0.511 (12.97)

Bases C and D provide clearance for motor-bosses with maximum dimensions of 0.5 in. Dia. x 0.15 in. high. Base E provides clearance for motor-bosses with maximum dimensions of 1.0 in. x 0.15 in. high

ORDERING INFORMATION

To order, complete the model number with code numbers from the table below:

Code 1: Model	Code 2: PPR	Code 3: Mounting Description	Code 4: Hub Bore Description	Code 5: Termination Description
M9	<input type="text"/> <input type="text"/> <input type="text"/> <input type="text"/> <input type="text"/> <input type="text"/>	<input type="text"/>	<input type="text"/> <input type="text"/> <input type="text"/> <input type="text"/>	<input type="text"/>
Ordering Information				
M9 0.9" Diameter Incremental Modular Encoder	0100/0	0 No mounting base	2.0 2.0 mm	1 5 pin header 2 flying leads
	0200/0	A 4x M1.6 on 0.728" BC,	2.5 2.5 mm	
	0256/0	C 2x #2-56 on 0.75" BC	3.0 3.0 mm	
	0500/0	D 3x #0-80 on 0.823" BC	4.0 4.0 mm	
	0512/0	E 2x #2-56 on 1.812" BC	125 0.125 in	
	Special Order Consult Factory for Lead Time & Price		156 0.156 in	
	0300/0		Special Order Consult Factory for Lead Time & Price	
	0360/0		1.5 1.5 mm	



WWW.DYNAPAR.COM

Headquarters: 1675 Delany Road • Gurnee, IL 60031-1282 • USA

Customer Service:
Tel.: +1.800.873.8731
Fax: +1.847.662.4150
custserv@dynapar.com

Technical Support
Tel.: +1.800.234.8731
Fax: +1.847.662.4150
northstar.techsupport@dynapar.com

European Sales Representative
Hengstler GmbH
Uhlandstrasse 49, 78554 Aldingen
Germany
www.hengstler.com